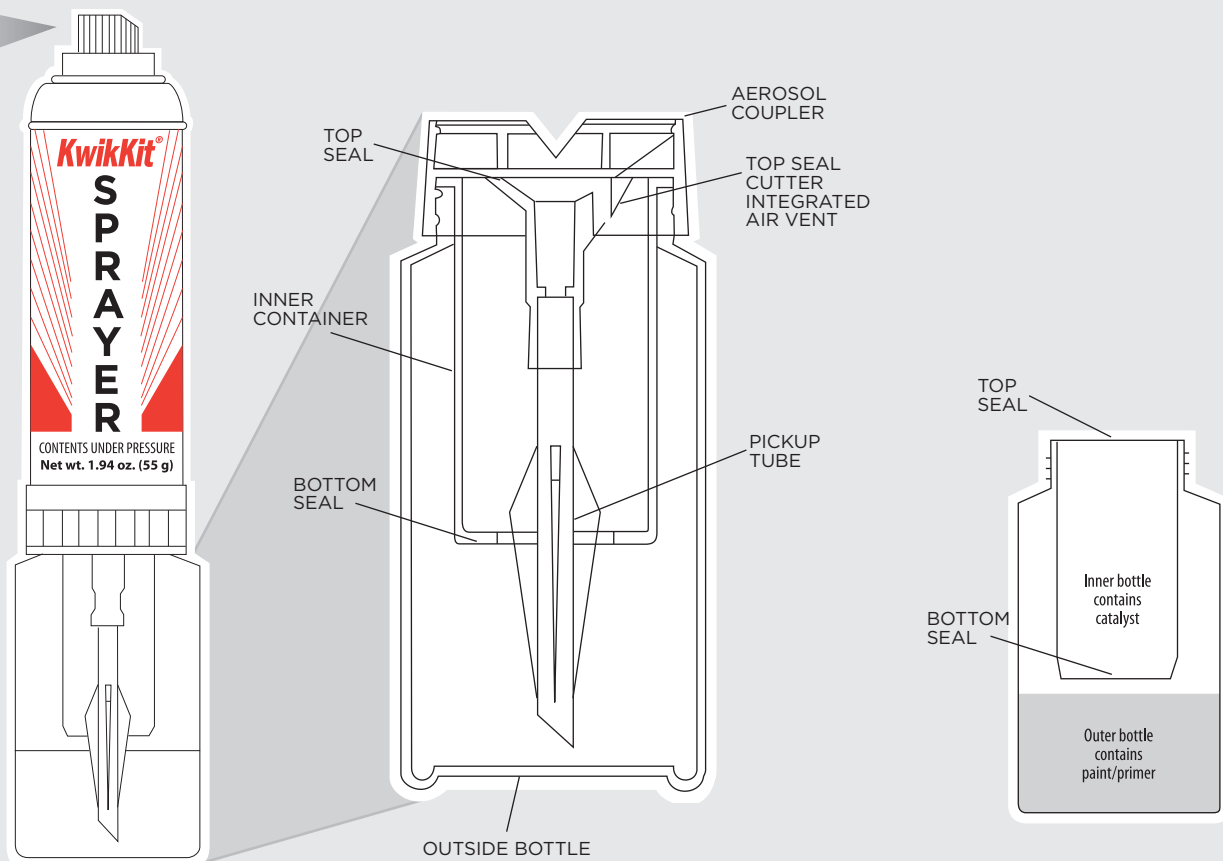

**KwikKit<sup>®</sup>****Small Quantity 2K Paint Touch-up Kit****PATENTED  
TECHNOLOGY**

For use on:

- ➔ **MILITARY VEHICLES**
- ➔ **AIRCRAFT**
- ➔ **GROUND SUPPORT EQUIPMENT**

All paints QPL'd to Military Specifications.

**GSA** Contract Holder  
 Contract GS-21F-0010W

- Meets SCAQMD Requirements.
- All-in-one 2 Component Paint Touch up Kit.
- Each self contained unit comes with sprayer.
- Each Kit provides coverage of approximately 6sq/ft.
- Reduce Paint Waste!
- Reduce Waste Cost!
- Convenient Application, Storage and Clean up.
- Currently used by MCAS Miramar, Camp Pendleton, MCAS Yuma.
- Packaged Six Complete Units to a box.
- No HAZMAT Shipping Required on ground.

*All components to this kit are engineered and manufactured in house! Thus, creating a rigid sealed unit, no leaks, improved airflow and atomization. Paint contents are packaged under dry Nitrogen for stability and extended shelf life.*

# KwikKit®

The KwikKit® packaging concept is a patented two-component paint/primer touch up kit. Unlike any others on the market, the KwikKit utilizes a “catalyst capsule” which insures the integrity of the catalyst. The “capsule” preserves and protects the catalyst from moisture and air. This also eliminates the end users need to remove upper portion and pour contents into bottle. Another feature of the KwikKit is the unique coupler and pick up tube, both pieces have been designed and engineered specifically for the KwikKit to allow proper ventilation and penetration of the inner capsule. In short, the KwikKit delivers a consistent means of spraying two-component materials without the mess, and inconsistent spray patterns often found with similar kits on the market, giving a continued even spray pattern every time.

Today's industry experiences a wide variety of needs for touch-up, e.g.: assembly rework, production rework, corrosion control, cosmetic touch-ups, and maintenance due to environmental conditions.

The KwikKit provides a unique method for applying paint related material for the above mentioned purposes. KwikKit contains 1.9-ounces of primer/paint. This kit was specifically designed for small area repair, or where conventional spray applications are not cost effective, or time efficient. KwikKit reduces cost of hazardous disposal when compared to conventional aerosol spray cans and is the only touch-up kit on the market to meet California APCD rules for coating applications.

The KwikKit is exempt from hazardous material shipping charges (ground only). Touch-up cost is a sum of (1) labor; (2) coating products, (3) HAZMAT control, and (4) waste disposal.

**1. LABOR:** Eliminates time of constituent proportioning. KwikKit used as an aerosol does not require special training. Reduces mixing more products than actually needed. Cleaning of spray equipment and solvents required minimized.

**2. INVENTORY CONTROL:** Significantly reduces bulk of stored materials and waste generated from expired products.

**3. HAZARDOUS MATERIAL CONTROL IS MINIMIZED.** Check out check-in one item.

**4. WASTE DISPOSAL IS MINIMIZED.** Remainder of mixed coating product will solidify after a few hours. Single container reduces bulk waste. Reducing the end users exposure to harmful vapors typically associated with conventional application of epoxies and urethanes will increase personnel safety. Flammable vapors are reduced with epoxies and urethanes applied through KwikKit, as no open containers are required during proportioning and mixing. The uniqueness of the KwikKit allows the end user to apply a two-component coating with the ease of an aerosol spray can.

## “WE GOT THE ORDER AND IT JUST HAPPENED TO SAVE THE DAY!...

One of the squadrons had to do some periodic maintenance on some gear which included a repaint. The gear was small enough that we were able to give them a couple KwikKits so they could repaint the gear at the squadron level. Your product enabled us to maintain our readiness which means the Harriers can fly the daily operations they need to. I'm happy to report your company has filled a much needed niche for the Navy/Marine Corps team and it's been a long time coming.”

Best regards,

**GYSGT. MARINE**, Airframes Mechanic, MCAS Yuma AZ